

REV	DESCRIPTION	WHO	DATE
A	RELEASED PER ORIGINAL SPECIFICATION		

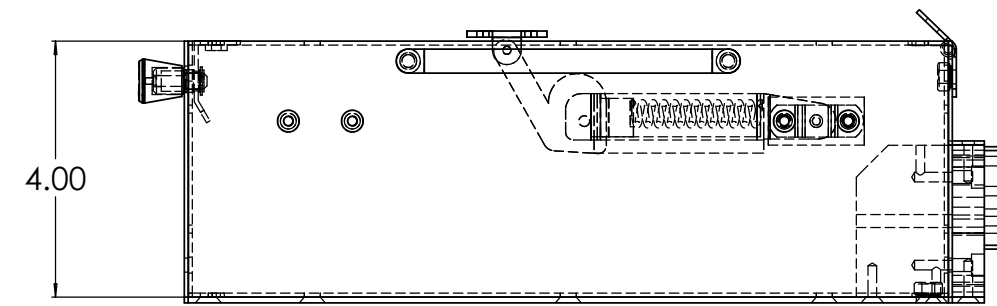
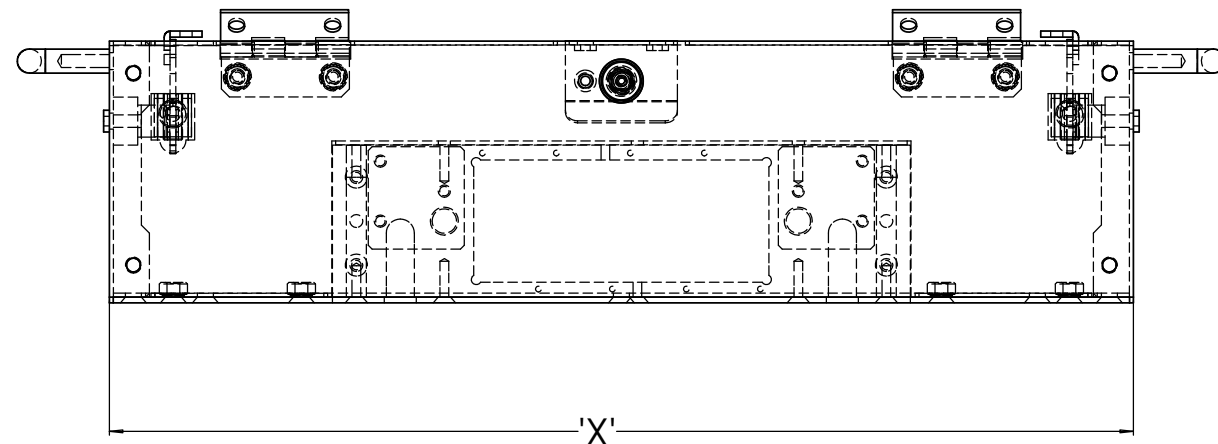
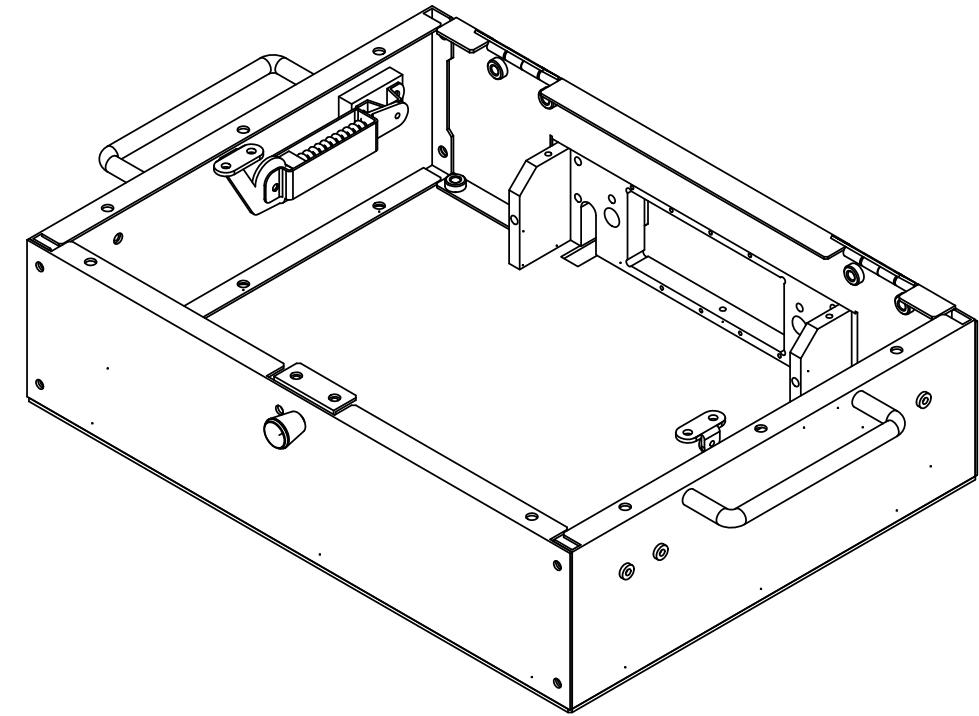
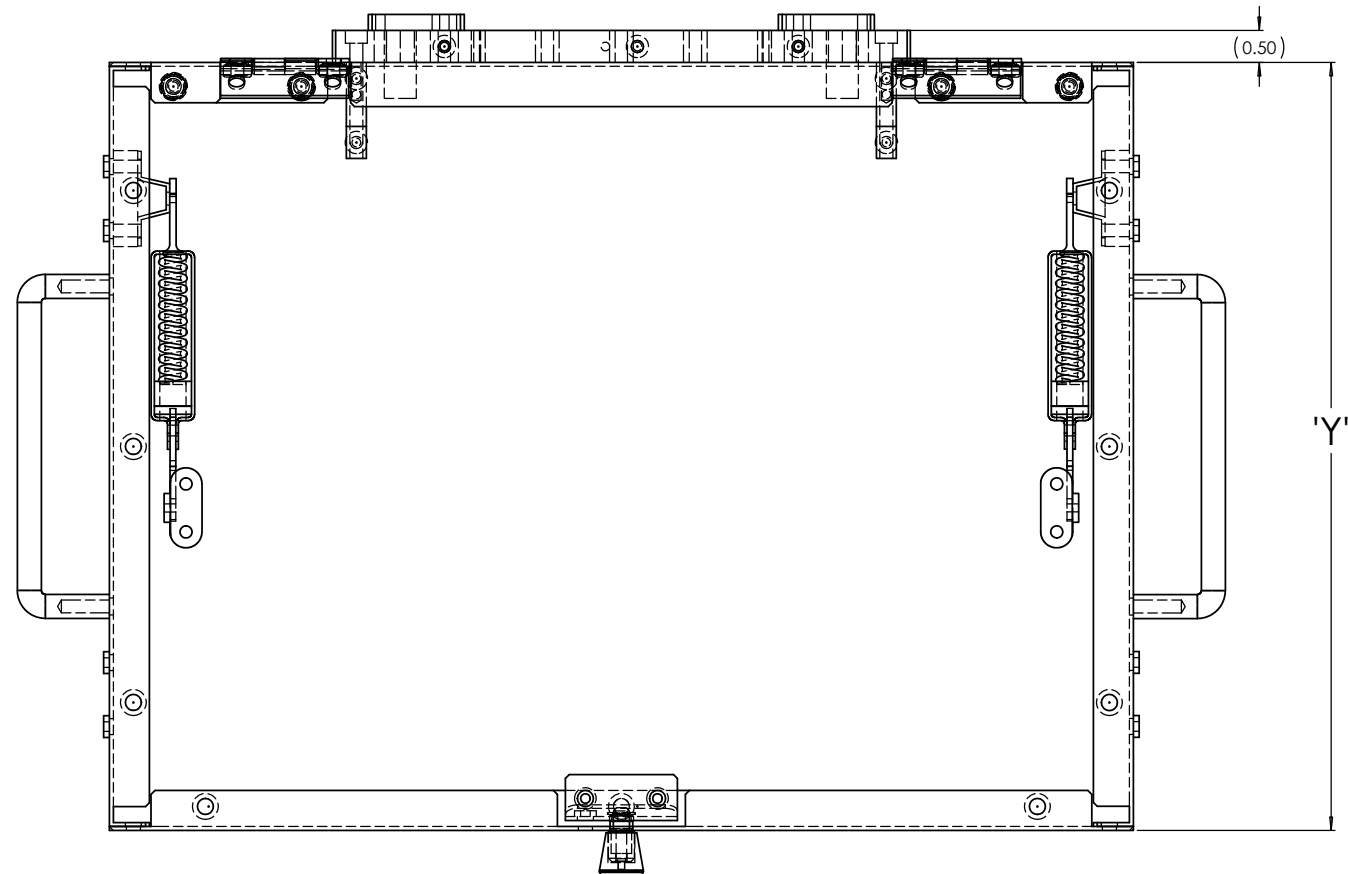

SERIES 3400 PAN DIMENSIONS			
ASM No.	X	Y	Z in
A3402	12.00" [304.8mm]	8.00" [203.2mm]	4.00"
A3403	12.00" [304.8mm]	16.00" [406.4mm]	4.00"
A3404	16.00" [406.4mm]	12.00" [304.8mm]	4.00"
A3405	16.00" [406.4mm]	20.00" [508mm]	4.00"

MATERIAL:		DRAWN BY:		14 HIGH STREET PLAINVILLE, MA. 02762																									
TREATMENT/FINISH:		DATE: 9/18/2024		(508) 384-8303																									
NEXT ASSEMBLY:		CHECKED BY:																											
INTERPRET GEOMETRIC & ELECTRICAL SYMBOLS PER ANSI STANDARDS		DATE:																											
UNLESS OTHERWISE SPECIFIED USE THE FOLLOWING:		DATE:		DESCRIPTION SERIES 3400 PAN DIMENSIONS																									
DEBURR & BREAK ALL SHARP EDGES APPROXIMATELY 0.01 ± 45°		DATE:																											
DRAWING VIEWS PROJECTED USING 3RD ANGLE		TOLERANCE OR DIMENSIONS		LAST SAVED BY:																									
		<table border="1"> <thead> <tr> <th></th> <th>125</th> <th>MAXIMUM MACHINE FINISH</th> <th></th> </tr> <tr> <th></th> <th>INCH</th> <th>METRIC</th> <th>DATE</th> </tr> </thead> <tbody> <tr> <td>2 PLACE</td> <td>±.01</td> <td>±.25mm</td> <td></td> </tr> <tr> <td>3 PLACE</td> <td>±.005</td> <td>±.127mm</td> <td></td> </tr> <tr> <td>4 PLACE</td> <td>±.0005</td> <td>±.0127mm</td> <td></td> </tr> <tr> <td>ANGLES</td> <td>±30'</td> <td>±30'</td> <td></td> </tr> </tbody> </table>			125	MAXIMUM MACHINE FINISH			INCH	METRIC	DATE	2 PLACE	±.01	±.25mm		3 PLACE	±.005	±.127mm		4 PLACE	±.0005	±.0127mm		ANGLES	±30'	±30'		APPROVED BY:	
	125	MAXIMUM MACHINE FINISH																											
	INCH	METRIC	DATE																										
2 PLACE	±.01	±.25mm																											
3 PLACE	±.005	±.127mm																											
4 PLACE	±.0005	±.0127mm																											
ANGLES	±30'	±30'																											
SEMCO PROPRIETARY THIS DOCUMENT IS THE PROPERTY OF SEMCO MACHINE CORPORATION. IT IS TO BE RETURNED UPON REQUEST. REPRODUCTION BY ANY MEANS, DISCLOSURE, OR USE OF ITS CONTENTS FOR WHICH IT IS LOANED, WITHOUT WRITTEN CONSENT OF SEMCO MACHINE CORPORATION IS STRICTLY PROHIBITED.		RELEASE DATE:		SIZE: D PART/ASSEMBLY NUMBER: SHEET 1 of 1																									