

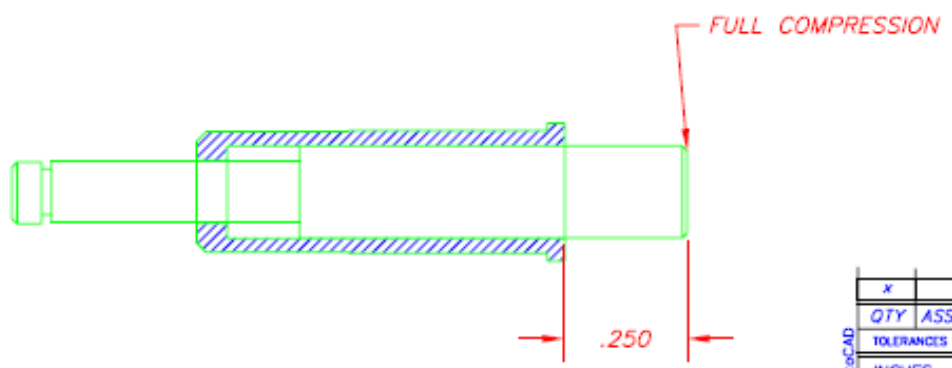

P\N	MATERIAL	MATERIAL DESCRIPTION	FINISH	REMARKS

NOTES:
1. DRILL HOLE SIZE .250 +/- .0005

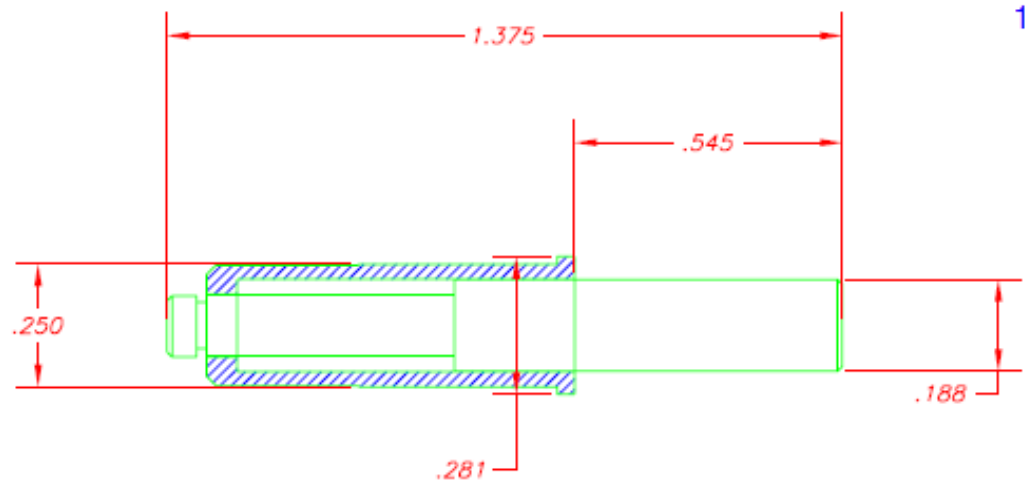

SEMCO PROPRIETARY

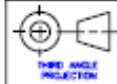
x	ASM No.	A	FIRST ISSUE		
QTY	ASSEMBLY NUMBER	ECN	REV.	REVISION	BY DATE APVD
TOLERANCES UNLESS OTHERWISE SPECIFIED:			APPROVALS	DATE	 SEMCO MACHINE CORPORATION 3 Kenneth Wier Drive Wrentham, MA 02093 (508) 364-8303
INCHES	ANGULAR	DESIGNED		1/14/02	
.X ± .02	±1°	F.J. HOLMES			
.XX ± .01		DRAWN		1/14/02	
.XXX ± .005		M. DOWDALL			
FRACTIONAL = STOCK SIZE			CHECKED		SPRING LOADED TP 1.1250 L W/ #4-40 TAP
DE-BURR ALL EDGES .020 MAX.			RELEASED	1/14/02	
CAD ADMINISTERED CHANGES ONLY			SCALE		DWG NO
			4:1		ASM-0076-02A
This drawing is the property of SEMCO CORPORATION. It is loaned with the understanding that it may not be reproduced nor may the information contained herein be used for the making of drawings or for manufacturing purposes without the written consent of SEMCO.					SHEET 1 OF 1
					REV. A